

HOWO Bitumen Distributor Truck

10Tons Capacity & Customized Rear Distributors

User's Manual



www.howotrucks.com/

Asphalt Distributor Truck

OWNER'S MANUAL

Content

Introduction	- 3 -
Precautions	- 4 -
View of intelligent asphalt distributor truck.....	- 6 -
I. Specifications of the Asphalt Distributor.....	- 7 -
II. Construction and Operation of Asphalt Distributor Truck System.....	- 8 -
(I) Asphalt Tank	- 8 -
(II) Power Train	- 9 -
(III) Asphalt Pump and Piping.....	- 10 -
(IV) Asphalt Heating and Heat Transfer Oil System.....	- 10 -
(V) Asphalt Pipe Cleaning System	- 12 -
(VI) Electrical Control System.....	- 12 -
III. Use and Operation of Asphalt Distributor Truck	- 13 -
(I) Preparations of Operation.....	- 13 -
(II) Asphalt Filling.....	- 14 -
(III) Operation of Asphalt Transport.....	- 17 -
(IV) Operation of Asphalt, Pipes and Asphalt Pump Heating	- 17 -
(V) Spraying of Asphalt.....	- 20 -
(VI) Cleaning of the Asphalt Pump and the Pipe	- 28 -
(VII) Completion of Construction	- 29 -
IV. Technical Maintenance and Lubrication.....	- 30 -
(I). Running-in Maintenance of a New Truck	- 30 -
(II) Technical Maintenance and Lubrication	- 30 -
V. Troubleshooting	- 32 -

Introduction

Intelligent Asphalt Distributor Truck is a machine specially designed for construction and curing of asphalt road surfaces, which is widely applied in operation, such as transport and distribution of **high-temperature liquid asphalt, emulsified asphalt and modified asphalt.**

Each model of CS TRUCKS's intelligent asphalt distributor truck uses Class II vehicle chassis equipped with an asphalt distributor which is finely developed by CS TRUCKS. The asphalt tank is covered with stainless steel sheets and is good in appearance. It has a good heat-insulating property due to application of aluminum silicate heat insulating material. The operation of the asphalt pump is controlled by hydraulic system and the transmission is stable, enabling safe and reliable operation. Asphalt can be sprayed evenly via the rear spray bar or the handheld spray bar according to the actual construction. Spraying via the rear spray bar is automatically controlled by the computer. The spray rate is under computerized control and is accurate. The asphalt pump and piping use heat transfer oil for heating and thermal insulation. The pipes and nozzles are flushed by compressed air, in order to avoid being clogged. The maximum spray width is up to 6m, and the spraying operation is high-efficiency and easy, with safe and reliable service behavior.

This manual will provide the precautions, specifications, basic principle of operation, operation instructions and troubleshooting for the general-purpose intelligent asphalt distributor truck. For normal operation of the asphalt distributor truck and high cost efficiency, please carefully read this manual before using this asphalt distributor truck for the first time and use, maintain and service it in exact accordance with the manual. For any question, please contact our after-sales service department, and we will gladly assist you. For use, maintenance and service of the chassis, refer to the attached "User's Manual" from the original manufacturer.

This manual is special used for this **SINOTRUK HOWO 8000L-1000L Intelligent Bitumen Distributor Truck.** Please carefully read it as well before using this asphalt distributor truck, and always operate and service truck in exact accordance with the manual.

Precautions

1. Owing to the very high surface temperature of the operating devices and pipes of the asphalt distributor truck during operation, please wear work clothes, gloves and helmet before working to avoid scalding.
2. For the first time a new truck is used, the amount of asphalt filled shall be less than 60% of the rated tank volume.
3. To fill hot asphalt, it is required to **drain off water remained in the tank**; otherwise, the hot asphalt may sharp expand and spray out when it meets cold water, which may result in a danger.
4. To change the material from emulsified asphalt to hot asphalt, the emulsified asphalt inside the tank must be removed completely; otherwise a danger may take place.
5. During the course of transporting and spraying, it's prohibited absolutely to allow people standing on the rear working platform of the asphalt distributor truck.
6. Once the vehicle is filled with hot asphalt, personnel other than those associated with operation shall be kept at least 5m away from the asphalt distributor truck for safety.
7. To ensure satisfactory spraying quality, for common roads with a heavy traffic, the temperature of asphalt shall be higher than **160°C**, higher than **185°C** for SBS and SBR modified hot asphalt, and within the range from **65 to 85°C** for SBS and SBR modified asphalt emulsion.
8. The allowable service temperature of heat transfer oil shall be not greater than **250°C**.
9. When emulsified asphalt is used, the bottom **settlings** of large storage tank shall not be filled into the asphalt distributor truck, or failure will result.
10. The asphalt pump seized must not be started up by force, and it cannot run before it is heated for slackness.
11. To change the material from hot asphalt to emulsified asphalt, the residual asphalt inside the asphalt pump, pipes, and tank must be removed completely so as not to lead to failure of operation.
12. Before shifting the power take-off, disengage the clutch first. Otherwise, the power take-off or truck transmission will be damaged.
13. The gearbox should be shifted to a higher gear during transportation and to a lower gear during spraying. Always disengage the clutch and then shift when the truck runs at low speed or is stopped.
14. The asphalt distributor truck shall be transported with the power take-off disengaged, the burner off and asphalt inlet and outlet valves closed. In addition, the heat transfer oil pump must be stopped. **Never use the burner during driving.**

15. **The main air supply switch of the working system must be turned off during transportation.**
16. The asphalt pump and pipes must be purged when a tank of asphalt is depleted.
17. After daily work, always drain off the asphalt remained in the tank.

howotrucks.com
whatsapp: 0086 136 4729 7999

View of intelligent asphalt distributor truck



Side view of intelligent asphalt distributor truck

1. Truck chassis 2. Hydraulic system 3. Heating system 4. Heat transfer oil system
5. Asphalt tank 6. Control system 7. Rear spray bar 8. Gasoline Generator



Rear view of intelligent asphalt distributor truck

I. Specifications of the Asphalt Distributor

Table 3 Specifications (cont'd)

Model	CS5180GLQ
Chassis model	SINOTRUK HOWO series
Drive Type	4x2 Left Hand Drive
Engine model	WEICHAI WP10.300E22
Power (kw)	220KW / 300HP
Displacement (L)	9.726
Transmission	HW19710 10-shift Manual, 10F & 2R
Wheelbase	4600
Tire model	12.00R20
Cab seating capacity (persons)	3
Overall size (mm)	8930×2500×3900
Curb weight (kg)	9850
Max. vehicle speed (km/h)	105
Max. Gradeability	31%
Driving speed during operation (km/h)	1.2~6.5
Rated capacity of asphalt tank (L)	8000-10000
Spray width (m)	0~4.5
Spray rate (L/m ²)	0.25~3.0
Allowable viscosity of working medium (Cst)	≤300
Max. air pressure of cleaning system (MPa)	0.6
Max. pressure of hydraulic system (MPa)	20

Table 2 Grades and Capacity of Oils

Name	Grade	Capacity (L)
Automobile fuel	Light diesel oil	145
Dynamo fuel	Gasoline #90 or higher	25
Hydraulic oil for the working devices	Anti-wear L-HM68	100
Heat transfer oil for the working devices	Great Wall #320	110
Fuel for asphalt heating	Light diesel oil	From fuel tank at chassis
Pipeline-purge diesel oil	Light diesel oil	75

II. Construction and Operation of Asphalt Distributor Truck System

Distributor Truck System

Intelligent asphalt distributor truck consists of truck chassis, asphalt tank, power train, asphalt pump, piping, asphalt heating system, pipe cleaning system and automatic control system.

(I) Asphalt Tank

The asphalt tank (as shown in Fig. 1) consists of inner tank, insulating materials, casing, baffle, combustion chamber, in-tank asphalt pipes, heat transfer oil pipes, air reservoir, oil filler, volume meter and trim plate. The tank body is an elliptical cylinder which is constructed with inner and outer steel plates welded together and filled with aluminum silicate heat insulating materials in between. It is 50 mm in thickness and is covered with stainless steel, which is good in appearance and easy to clean. It is equipped with a sink duct at the bottom which facilitates sucking all asphalt in the tank. At the bottom of the tank, five mounting legs and an auxiliary beam are welded into a single unit that is fixed to the truck frame. The outer course of the combustion chamber accommodates the heat transfer oil and a row of heat transfer oil heating tubes are installed at the bottom. The volume meter is used to indicate the level of asphalt in the tank. The oil filler is composed of two parts. The underneath cover should be opened when required to enter the tank for service, only the cap is opened usually for asphalt filling.

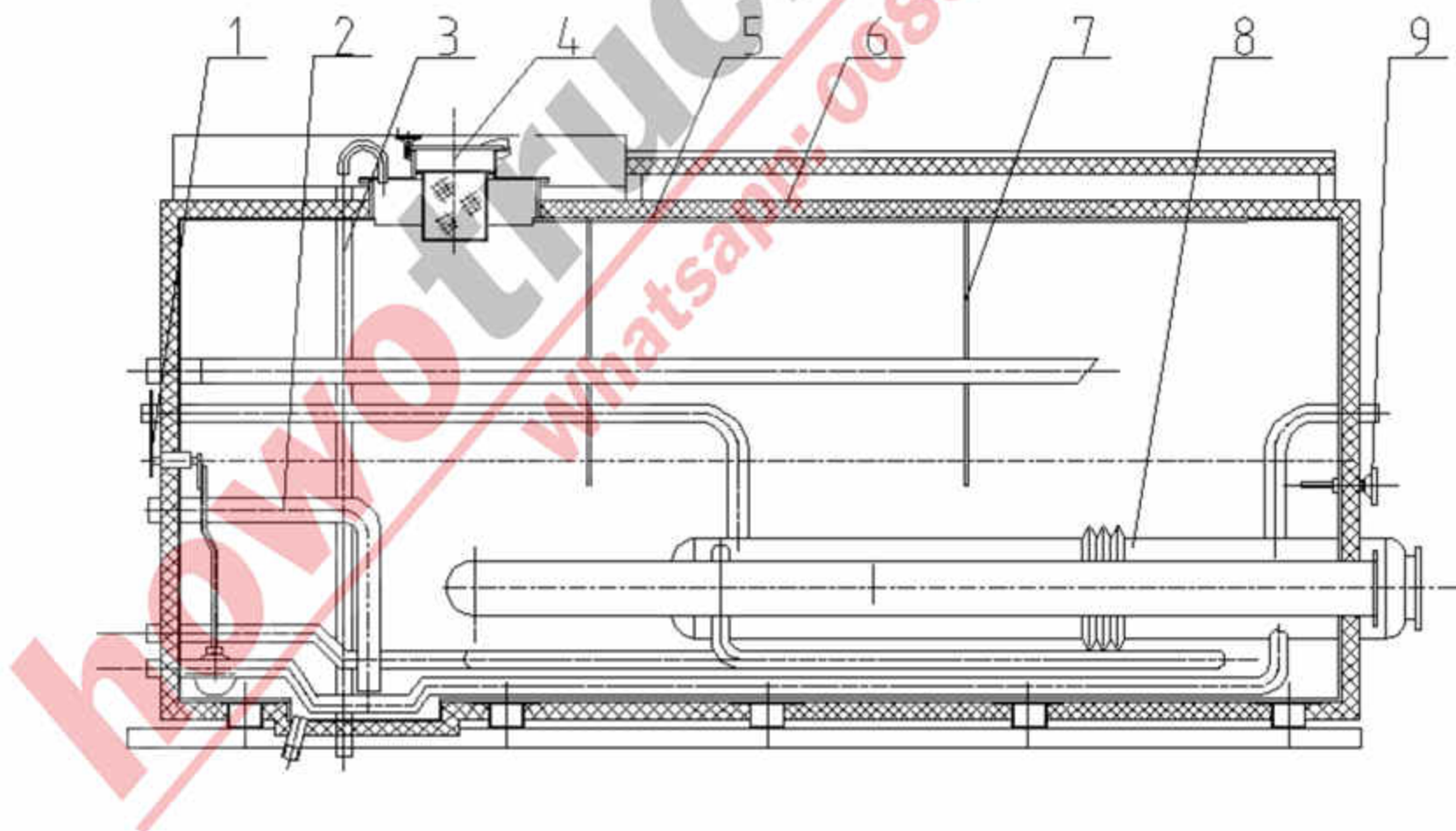

Fig. 1 Asphalt tank

1. Volume meter 2. Oil sucking pipe 3. Overflow pipe 4. Oil filler 5. Inner tank
 6. Heat insulating material 7. Baffle 8. Combustion chamber 9. Thermometer

(II) Power Train

The power train is composed of a power take-off, a pump transmission and a hydraulic system.

The power take-off is a mechanical gearbox structure with two shafts. The input gear is engaged with the 3rd gear of intermediate shaft of the truck transmission and the output shaft outputs the power. The shift fork will be driven by compressed air to achieve gear engagement or disengagement by engaging gear sleeve. The pump transmission consists of plug-in rubber coupling, universal drive shaft, and hydraulic pump mounting base, which transmits the power from the power take-off to the hydraulic pump.

The hydraulic system (as shown in Fig. 3) consists of hydraulic pump, overflow valve, reversal valve, hydraulic motor, and hydraulic pipes, which transmits the power from the hydraulic pump to the asphalt pump through the hydraulic motor.

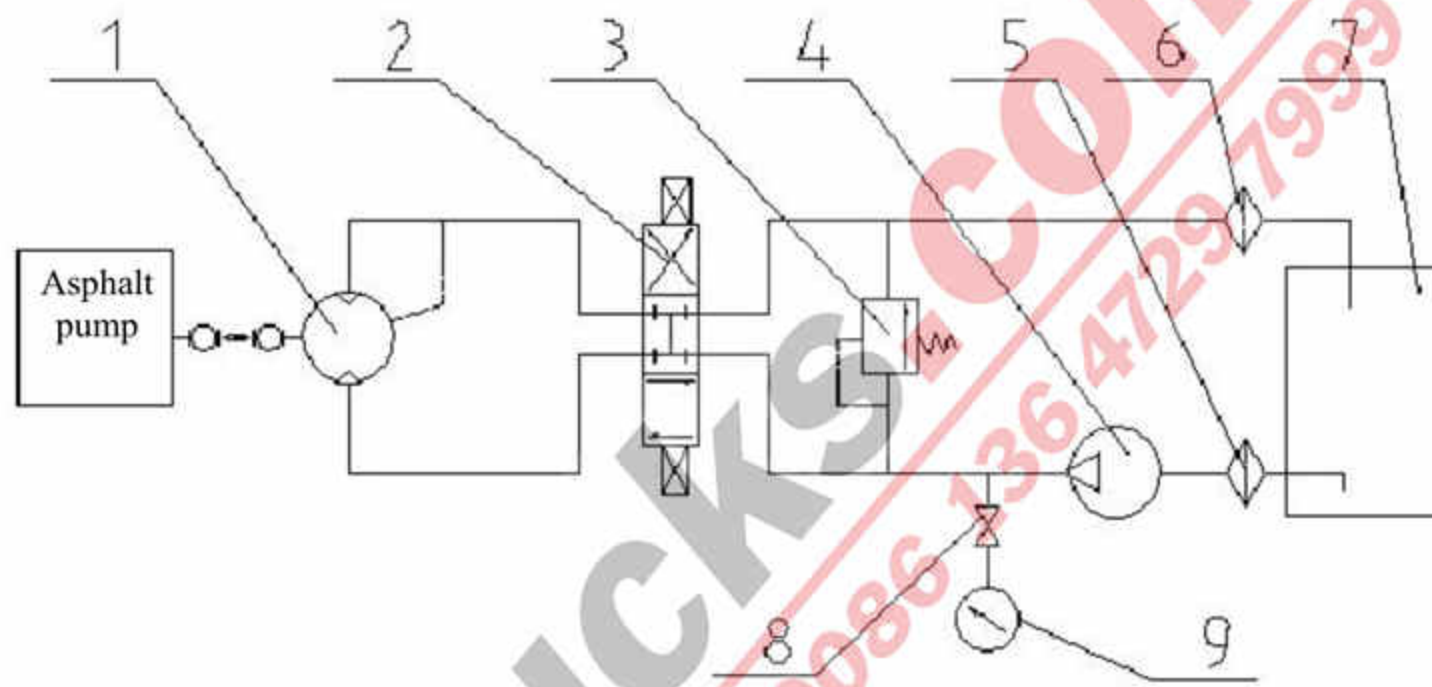

Fig. 2 Hydraulic system

- 1. Plunger motor 2. Reversal valve 3. Overflow valve 4. Variable displacement pump 5. Suction filter
- 6. Return line filter 7. Hydraulic oil tank 8. Pressure gauge switch 9. Pressure gauge

(III) Asphalt Pump and Piping

The asphalt pump and piping (as shown in Fig. 3) consists of asphalt pump, filter, valves, spraying pipes, and cylinder nozzle. They are mainly used to fill asphalt by self-suction, and to spray asphalt via rear spray bar or handheld spray bar.

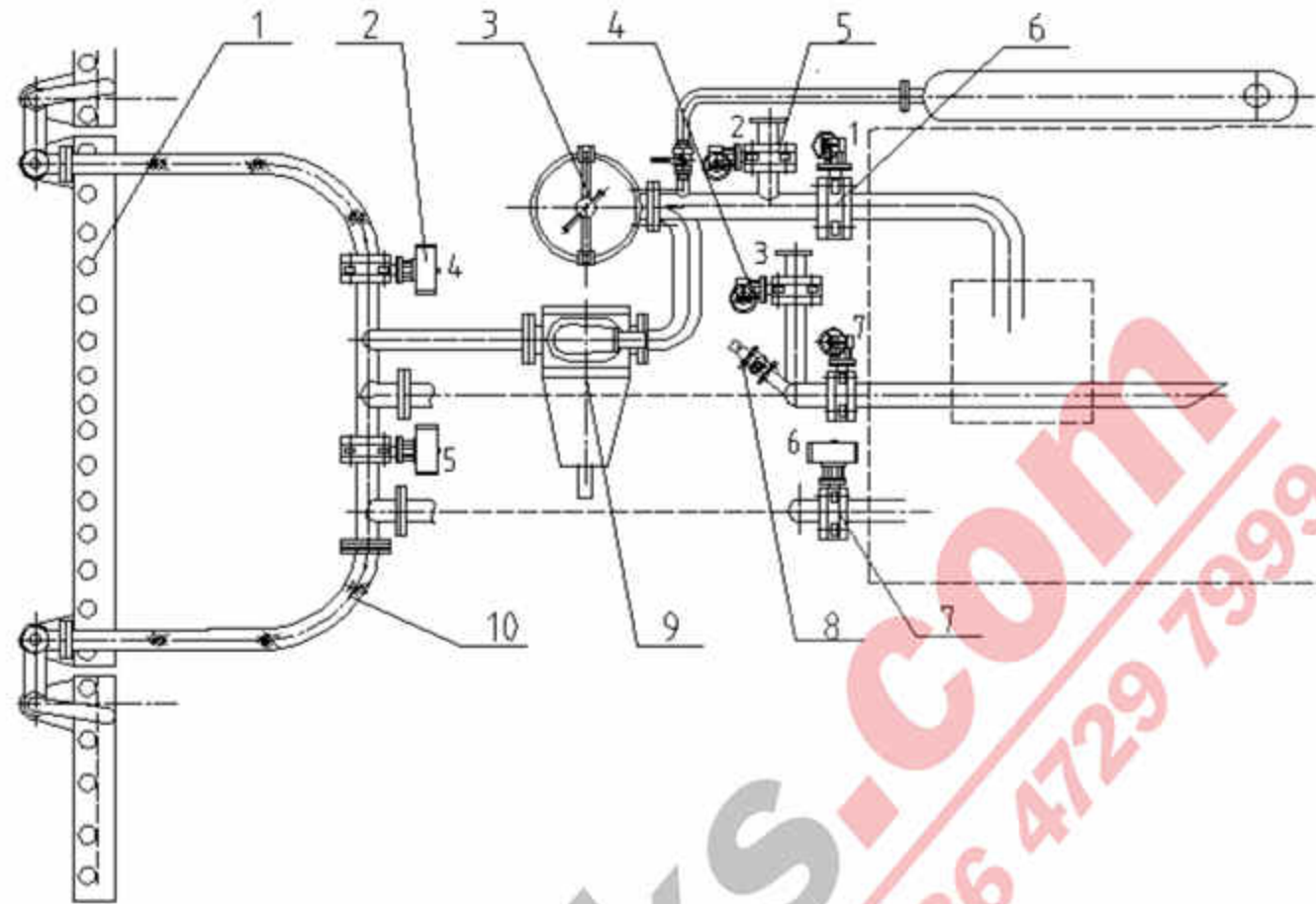

Fig. 3 Asphalt pump and piping

1. Cylinder nozzle assembly 2. Oil outlet valves (Nos. 4 and 5) 3. Filter 4. Transfer valve (No. 3)
 5. Self-suction valve (No. 2) 6. Oil inlet valve (No. 1) 7. Pneumatic oil return valve (No. 6)
 8. Handheld spray bar valve 9. Asphalt pump 10. Stainless steel hose

(IV) Asphalt Heating and Heat Transfer Oil System

The asphalt heating system consists of combustion heating system and heat transfer oil circulation/heating system.

1. The combustion heating system (as shown in Fig. 4) consists of U-shape combustion chamber, heat transfer oil heating chamber, fuel tank (i.e. main fuel tank of the truck), burner, and temperature control box. The diesel from the main fuel tank of the truck reaches the burner through the filter, is mixed with air, atomized, and sprayed into the combustion chamber for combustion. The exhaust gas is discharged from the flue. The heat around the combustion chamber can heat the asphalt inside the tank. The size and temperature of flame can be regulated via the temperature control box.

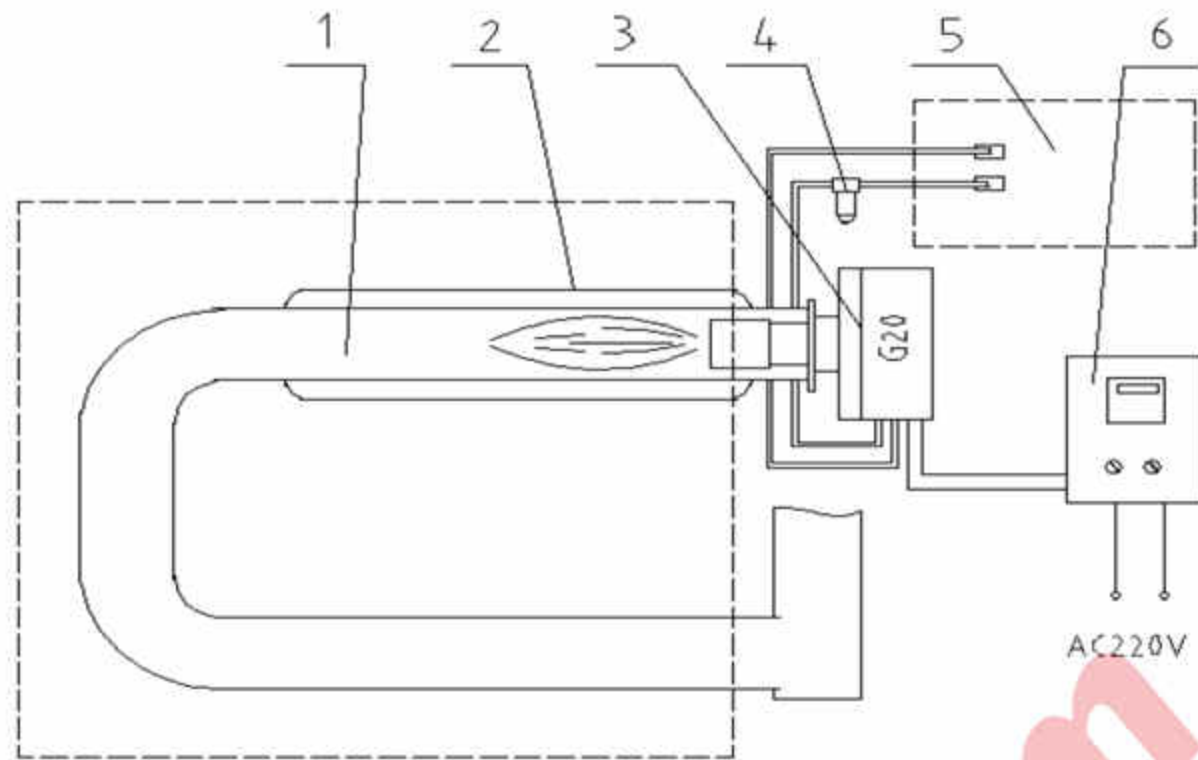

Fig. 4 Asphalt heating system

1. U-shape combustion chamber 2. Heat transfer oil heating chamber 3. Burner 4. Diesel filter
 5. Main fuel tank 6. Temperature control box

2. The heat transfer oil circulation/heating system (as shown in Fig. 5) consists of heat transfer oil pump, heat transfer oil expansion tank, asphalt heating/circulation pipes, and spraying system heating/circulation pipes. The heat transfer oil from the heat transfer oil heating chamber by the heat transfer oil runs in three paths as follows: a. from heat transfer oil pump, via (upper) oil outlet stop valve and in-tank heating pipes, to heat transfer oil heating chamber; b. from heat transfer oil pump, via (middle) oil outlet stop valve, asphalt filter, asphalt pump, and oil return pipe (for small circulation) or oil return pipe (for big circulation), to heat transfer oil heating chamber; c. from heat transfer oil pump, via (lower) oil outlet stop valve, bottom cross pipe, left spray bar and right spray bar, to heat transfer oil heating chamber.

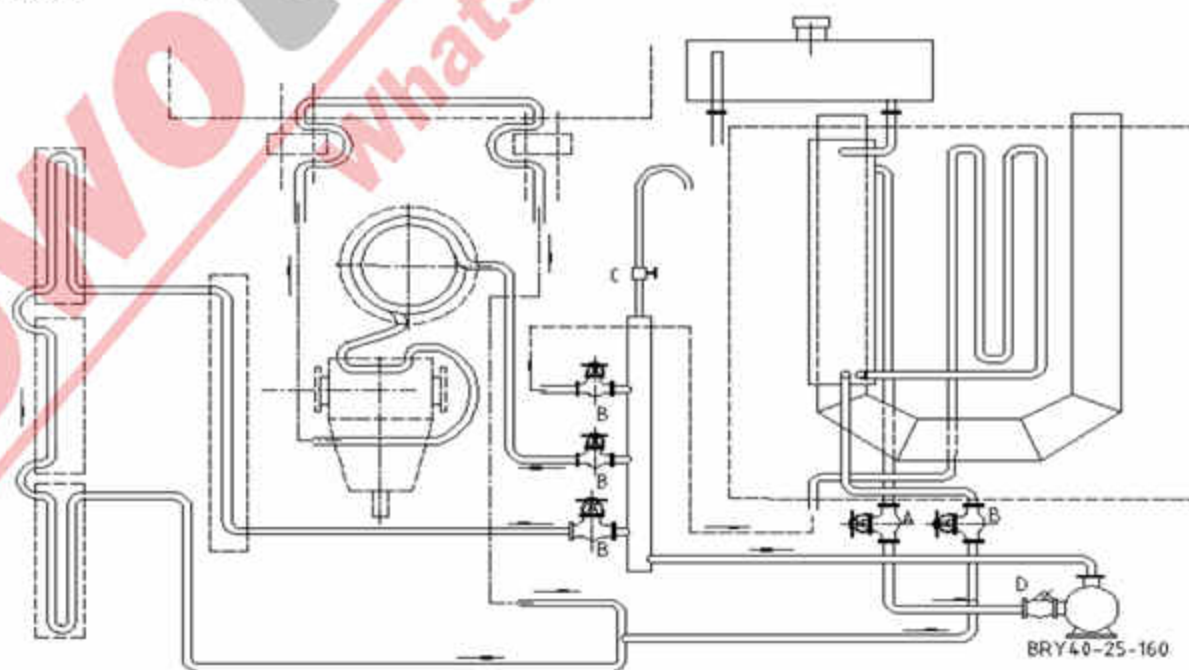

Fig. 5 Heat transfer oil circulation/heating system

- A: 1.5" stop valve B: 1" stop valve C: 1/2" high-temperature ball valve D: Heat transfer oil pump

(V) Asphalt Pipe Cleaning System

The pipe cleaning system (as shown in Fig. 6) includes the diesel cleaning and compressed air flushing parts. The diesel cleaning part is composed of a diesel tank (cylinder), oil inlet copper ball valves and pipes. The compressed air flushing part is composed of an air reservoir, check valve and air valve. For cleaning with diesel, run the asphalt pump at low speed, allow the diesel to go through the oil inlet copper ball valve, filter and asphalt pump, and discharge from the nozzles. For flushing with compressed air, close the diesel valve, run the asphalt pump at low speed, open the main pipe air valve, and the compressed air will pass through the valve, filter, asphalt pump and rear spray bar, and get out from the nozzles, in order to remove the asphalt and diesel remained in the pipes. The check valve can prevent the asphalt from returning to the air reservoir.

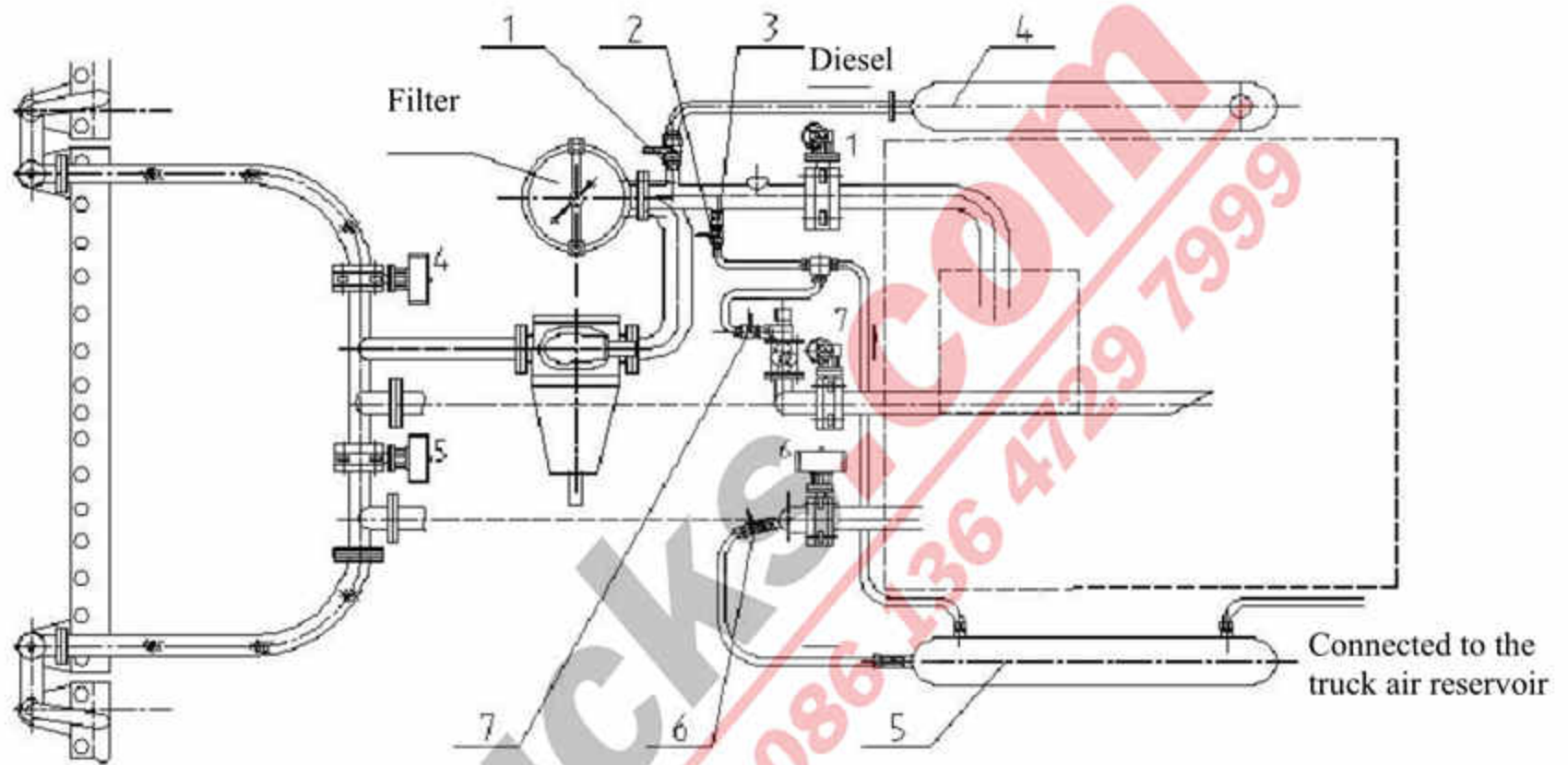

Fig. 6 Pipe cleaning system

- 1. Oil inlet copper ball valve 2. Main pipe air valve 3. Air check valve 4. Diesel cleaning tank
- 5. Air reservoir 6. Oil return pipe air valve 7. Handheld spray bar air valve

(VI) Electrical Control System

The electrical control system is divided into two parts, the DC circuit (DC24V) and the AC circuit (AC220V). The DC circuit is composed of power take-off, gearbox, cooler, hydraulic reversal valve, and rear spray bar lifting, rear working light control and automatic control system circuits. The AC circuit consists of generator, burner, and heat transfer oil motor circuits. See the appendix for details on electrical diagram of intelligent model.

III. Use and Operation of Asphalt Distributor

Truck

Using the asphalt distributor truck correctly and observing regulations associated with operation can give full play of the mechanical efficiency, keep the machinery in good condition, thus improving the productivity and reducing the construction cost. Use and operate the asphalt distributor truck according to the operation processes below.

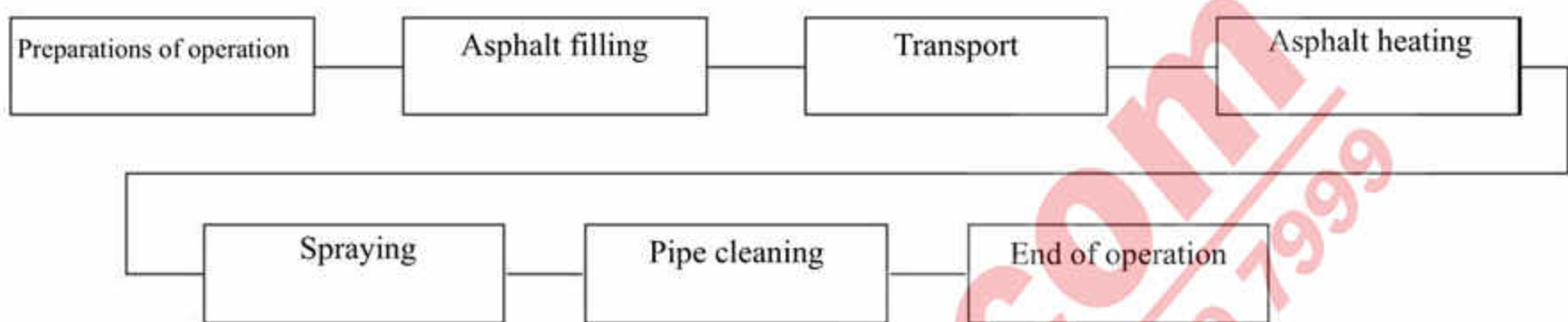

Operation flow chart of the asphalt distributor truck

(I) Preparations of Operation

Carefully check the items below and ensure that there is no fault before filling asphalt into the tank.

1. Check the steering, braking, electrical and traveling devices of the vehicle for normal and reliable operation.
2. Check that the engine lubricating oil, fuel and cooling water are enough and that there is no leakage.
3. Check that the generator lubricating oil and fuel are enough.
4. Fill proper amount of diesel (around 60 to 70 liters) into the diesel cleaning tank (cylinder).
5. Close all valves of piping, especially the diesel inlet copper ball valve and air valve; otherwise, asphalt will be returned to the air reservoir or diesel tank, thus causing a fault.
6. Check that the rear spray bar or the handheld spray bar and the nozzles are unblocked, and that the asphalt pump can run normally.
7. Put the transmission and power take-off into the neutral position before starting the engine.

8. Start the engine and shift the power take-off, and check the hydraulic system and all the electrical switches for normal operation.
9. Check the generator, heat transfer oil pump and burner for normal operation.

(II) Asphalt Filling

The asphalt can be filled by two methods, that is, either from an **off-vehicle equipment** or by **self-suction of the asphalt pump**.

Method 1: Filling asphalt from an off-vehicle equipment

After verifying that no failure exists, drive the distributor truck to the position under the filling pipe. Close all valves first, open the oil filler cap on top of the tank (as shown in Fig. 7), and insert the oil filling pipe to start filling asphalt. After filling, securely tighten the oil filler cap.



Fig. 7 Asphalt tank oil filler

Pay attention to the following when filling asphalt:

1. Never fill the asphalt tank excessively, especially for hot asphalt, so as to avoid an overflow.
2. The filled asphalt must reach the following temperature. If the heating duration is too long, that will cause adverse effect on the service life and the efficiency of the equipment. For common roads with a heavy traffic, the temperature of hot asphalt shall be higher than

160°C, higher than 185°C for SBS and SBR modified hot asphalt, and within the range of 65-85°C for SBS and SBR modified asphalt emulsion.

3. For the first time a new truck is used, drain off the water accumulated in the tank to avoid an accident, and the amount of asphalt filled shall be less than 60% of the tank volume.
4. After emulsified asphalt is used, make sure to drain off the remaining emulsified asphalt thoroughly before filling hot asphalt; otherwise, danger will be caused.
5. Regularly check if the breather is unblocked.

Method 2: Filling asphalt by self-suction of on-vehicle asphalt sucking pump

Drive the distributor truck to a place near the asphalt storage tank (within 5 meters), and securely connect the self-suction hose as shown in Fig. 8. Insert the hose to the storage tank, open the valve (No. 1) as shown in Fig. 8, close the valve (No. 2), close the valve (No. 3), and open the valve (No. 4). Turn the “Control Selection” switch on the rear console, to the “Rear Console” position, the “Asphalt Control Valve” to the “Self-suction Oil” position, and the “Control Mode” switch to the “Manual” position. In this case, the two oil outlet valves (Nos. 4 and 5) under the rear operation platform shall be turned to the “Off” position. Start the truck engine, shift the power take-off, turn on the “Asphalt Pump” switch, and turn up the speed regulation knob. The engine speed shall be held at 2000 rpm.

Open the cap of the oil filler on the top of the tank (as shown in Fig. 7) and check if asphalt flows through the oil return pipe. If no asphalt flows after the asphalt pump has run for 1 to 2 minutes, **immediately stop** the pump. Check for any blockage or air leakage in self-suction pipe, valves or filter.

If the asphalt pump is seized by asphalt and cannot rotate, light the burner and use the heat transfer oil to warm up the asphalt pump. For this method, please refer to the section Heating of Asphalt Pump and Pipes.



Note: Please Clean the Filter Every Month!

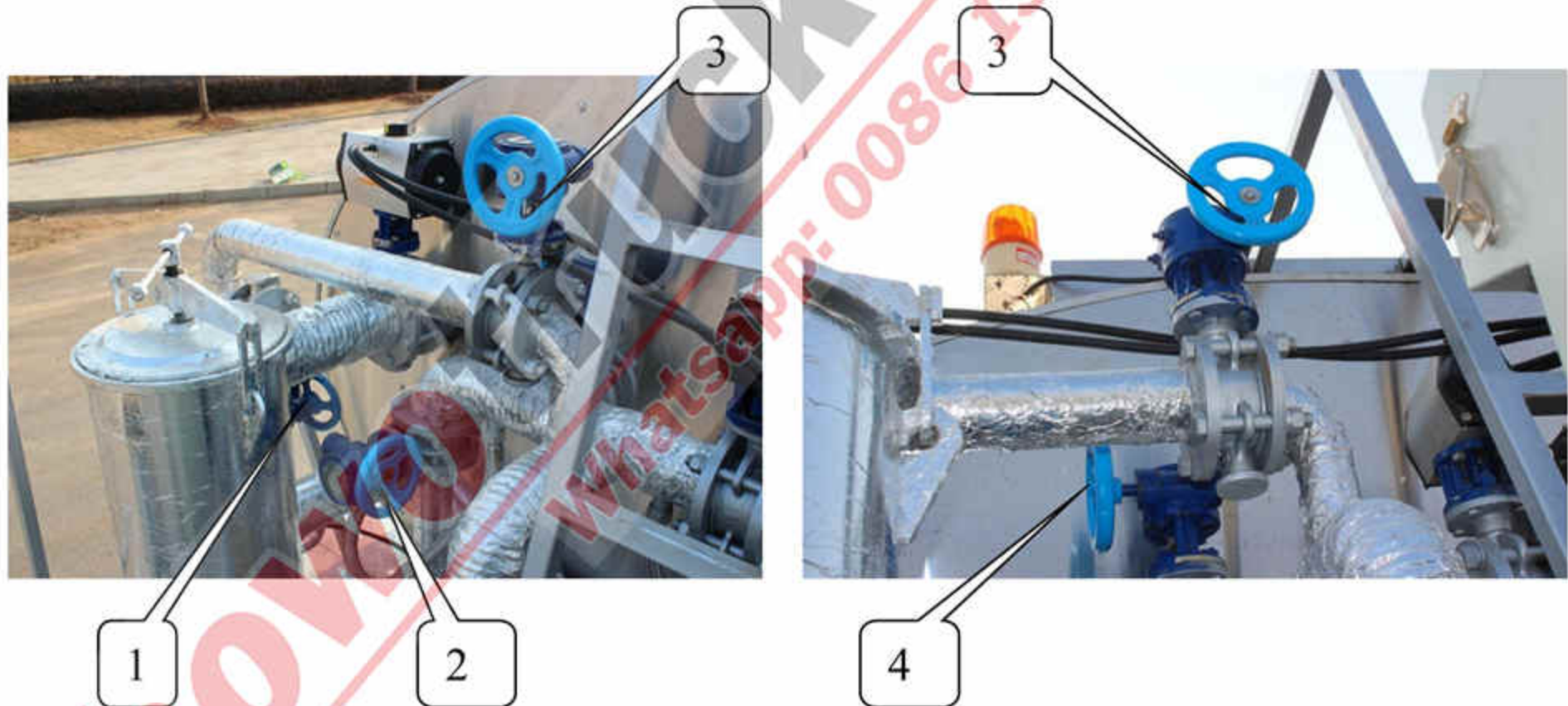

Fig. 8 Operation valve for self-suction

Valves Control Steps for Self-suction:

1. Bitumen Into the tank: Open Valve 1, Close Valve 2, Close Valve 3, Open Valve 4.
2. Bitumen for Spraying: Close Valve 1, Open Valve 2, Open Valve 3, Close Valve 4.

 **Pay attention to the following when filling asphalt:**

1. The self-suction hose must be tightly connected, and the cap of the asphalt filter must be tightly compressed to prevent air leakage. The diesel cleaning valve and air valve must be

tightly closed; otherwise, they cannot work.

2. Make sure that the asphalt level of the storage tank is higher than the center of the asphalt pump, with a distance less than 5 meters.
3. Do not idle the asphalt pump for more than 2 minutes.

Other precautions are the same as those for Method 1.

Please Note: Since the asphalt pump works under high temperature, the inner clearance is fairly large. Long self-suction will result in quick abrasion. Therefore, CS TRUCKS recommends minimizing the use of Method 2.

(III) Operation of Asphalt Transport

After the asphalt distributor truck has been filled up, truck clutch should be released and the gearbox should be engaged to the high speed gear (transportation gear). Then the truck should start slowly and runs to the site with the medium speed kept.



Pay attention to the following when transporting asphalt:

1. **Persons are absolutely prohibited to stand** in the rear operation platform during transportation.
2. The power take-off must be in neutral position, and **use of the burner is absolutely prohibited** during traveling.
3. Shut off all valves, especially the main air supply valve of the control system (which is located on the air reservoir of the truck chassis).
4. Minimize the use of high speed driving and emergency braking.

(IV) Operation of Asphalt, Pipes and Asphalt Pump Heating

The asphalt filled into the tank after transported to the site must be heated up if its temperature does not meet the requirement for distributing operation and the method is as follows:

1. Park the distributor truck in a flat, level place, shift the truck transmission to the neutral position, and start the truck engine. After that, shift the power take-off and enable the main air supply valve of the control system (which is located on the air reservoir of the truck chassis).
2. Keep the funnel clear.

3. Start the generator (as shown in Fig. 9). Also, an external power supply can be used.
4. Turn on the "Burner" switch. After that, sounds from burner fan rotation can be heard until the burner ignites.



Fig. 9 Gasoline Generator

5. If the burner cannot be lit and stop automatically. If the burner cannot be ignited by several attempts, check the oil inlet rubber hose for any leakage or carbon deposits on the nozzle or the ignition electrode.
6. After the burner ignites, the thermostat will automatically control its combustion or stop via the heat transfer oil temperature sensor (at the heat transfer oil riser behind the tank).
7. After heating up, turn off the "Burner" switch and combustion will be stopped.



Fig. 10 Asphalt heater

1. Reset button 2. Burner 3. Nozzle 4. Combustion chamber

Asphalt heating:

1. After the burner is ignited, open the oil inlet valve on the heat transfer oil pipe and asphalt heating valve (as shown in Fig. 11), and close the asphalt pump heating valve and asphalt pipe heating valve.
2. Switch on the “Heat Transfer Oil Pump” switch in the temperature control box (as shown in Fig. 9), and the heat transfer oil pump will rotate. Check if the output pressure of heat transfer oil pump is 0.1 - 0.15MPa. In this case, the heat transfer oil just circulates internally.

Heating of Asphalt Pump and Asphalt Pipes:

Open the heat transfer oil pipe inlet valve and oil return valve (as shown in Figure 11) and close the asphalt heating valve. Open the asphalt heating pump valve and asphalt heating pipe valve. In this case, the heat transfer oil just circulates externally to heat the asphalt pump, asphalt pipe and nozzles.



Fig. 11 Heat transfer oil valve

During asphalt heating, rotate the asphalt pump so that the asphalt inside the tank can be evenly heated.



Pay attention to the following when heating the asphalt:

1. When driving the distributor truck, **never use the burner or rotate the heat transfer oil pump.**
2. After the ignition of the burner, the operator shall not leave the distributor truck to prevent the burner against self-extinguishment.
3. If the flame of burner self-extinguishes, do not ignite it at once but wait for 1 ~ 2 minutes.
4. Due to small power of distributor truck burner, the burner can only be used for thermal insulation and small temperature rise, which is not applicable to achieve high temperature rise. It shall not be used as an oil melting stove.
5. If the indication light of heat transfer oil (Fig. 9) is lit, it means insufficiency of the heat conducting oil volume and it must be filled up, or ignition cannot be carried out.
6. The allowable service temperature of heat transfer oil shall be not greater than **250°C**.
7. Do not use the burner when the asphalt level in the tank is lower than the combustion chamber.

(V) Spraying of Asphalt (Please read carefully before operation)

After the temperature of asphalt inside the tank meets the spraying requirement, drive the asphalt distributor truck to the position where the rear spray bar is 1.5 to 2 meters away from the starting point of operation and park it there firmly. According to the construction requirements, the operator can spray asphalt via **automatic spray by front console**, **manual spray by rear console**, or **handheld spray bar**. The detailed operation is as follows:

Automatic spray via rear spray bar by front console:

1. As shown in Fig. 12, remove the hook, turn on the “Lifting” switch on the rear console, put down the spraying tube, and then open the left and right spray bar, with the nozzles about 250mm from the ground. The height could be adjusted with the chain.



Fig. 12 Rear spray bar

1. Air reservoir nozzle assembly 2. Rear spray bar hook 3. Rear spraying bar 4. Adjusting chain
 5. Lifting System 6. Lifting System Control Button 7. Rear Control System



Lifting System Control Button:
 Up: The lifting legs going up
 Down: The lifting legs going down

2. Start the truck engine and shift the gearbox to the low position (i.e. working position). If shifting cannot be achieved, shift the truck transmission to the 1st gear, and shift the gearbox again after appropriately driving the truck. Shift the truck transmission to the neutral position, shift the power take-off, and the hydraulic system will start operation.



Firstly make sure the Pressure over **0.6Mpa**, and then start other operation

3. Close Valve 1 & Valve 4, and Open Valve 2, the Pneumatic will control the bitumen outlet of tank.

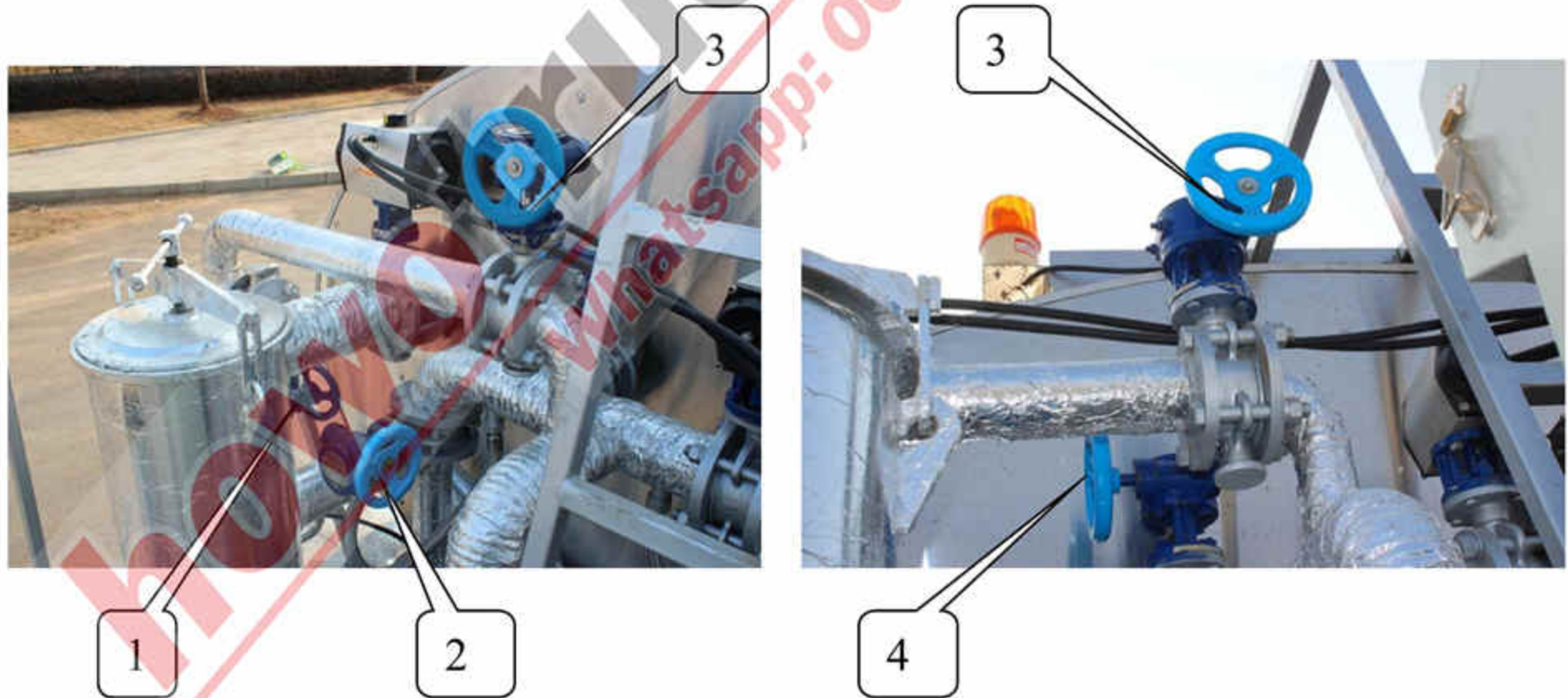
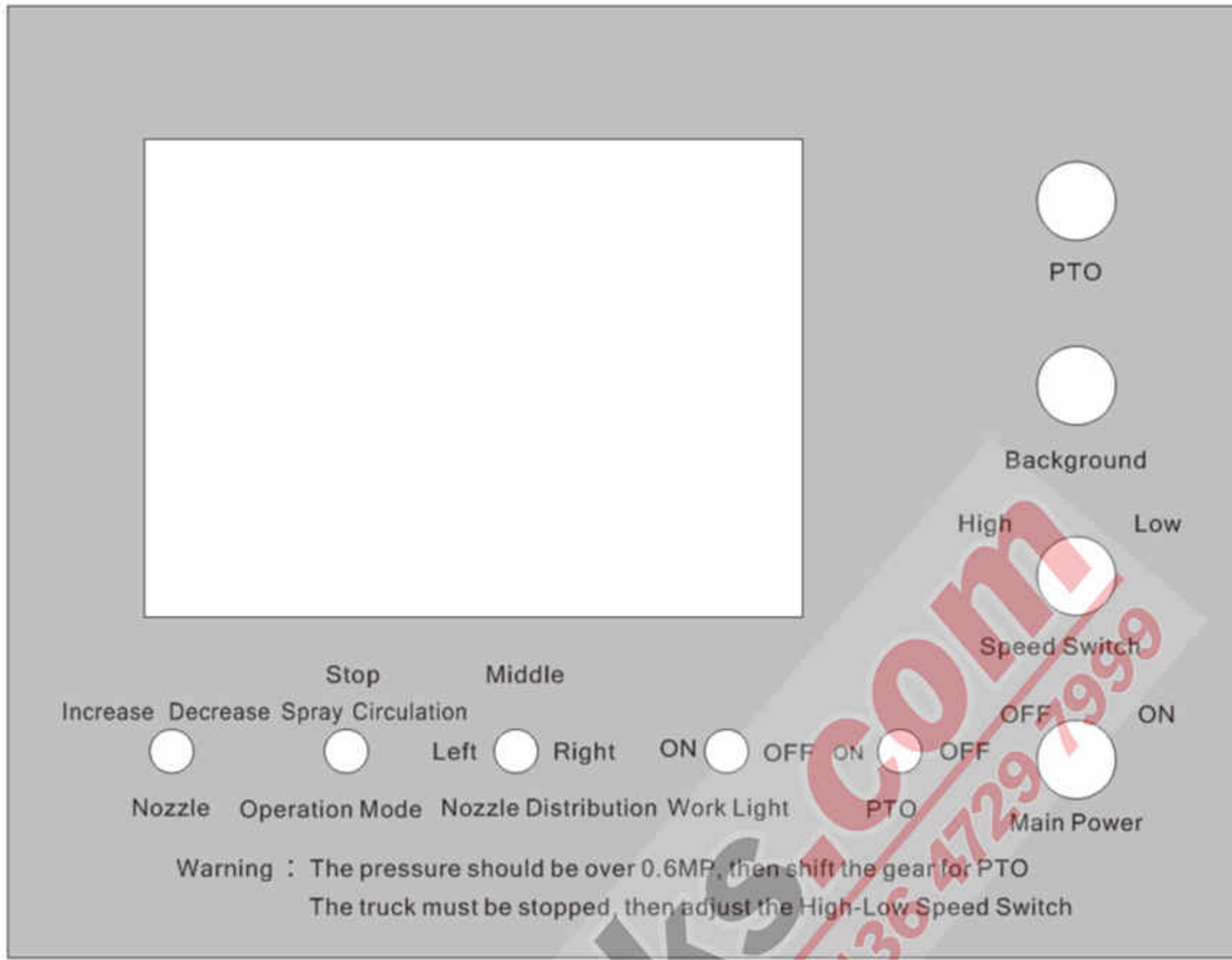

Fig. 13 Operation valve for spraying

4. Front Control Box (**Major**) Operation Introduction: (The parameters have been set, please do not amend anything)



Main Power button: Control the whole system, turn on the button firstly, then you can control the Front Control Box & Rear Control Box

Speed Switch button (Truck Speed): Truck at high speed, spray volume is less per square;
 Truck at low speed, spray volume is more per square.

Background lamp: When the Rear Control Box Main Power Button turns on, this lamp bright.

PTO Switch & PTO lamp: when PTO Switch turns on, the PTO lamp bright, the PTO starts working.

Working Light Switch: When Working Light Switch turns on, the working light on the top of tank bright.



Nozzle Distribution: control the Left & Middle & Right Distribution Nozzle

Operation Mode: Left-For Spraying; Middle-For Stop; Right-For Bitumen Circulation

Nozzle: Left-For Increase Nozzle quantity; Right-For Decrease Nozzle quantity



(Touch Screen Control Panel)

Operation Steps:

Firstly, When the Pressure is over 0.6Mpa, Turn the *Main Power* button to ON

Secondly, Turn *PTO Switch* to ON, the *PTO Lamp* bright. And PTO starts to work.

Thirdly, The operation for the **Touch Screen Control Panel**:

Turn Bitumen Pump button to ON;

Large Circulation to ON, Delivery to ON;

If the Bitumen temperature not enough, you should turn the Burner Button to ON;

If need Interval spray, you can turn the Interval Button to ON, showing as below:



Fourthly, While the spray working on, you can choose to do following operations:

Turn the *Nozzle Distribution Button* to control the Nozzle to spray or not, to Middle (Count from middle, Normal use), to Left (Count from left), to Right (Count from right).

Turn the *Operation Mode Button* to Right for heating the bitumen, or to Left for spraying the bitumen.

Turn the *Nozzle button*, to Increase (Increase the spraying nozzle quantity), to Decrease (Decrease the spraying nozzle quantity)

Turn the *Speed Switch Button*, to High (Truck at high speed, and the spray volume is less per square), to Low (Truck at low speed, and the spray volume is more per square).

**Please Note: All Parameters Setting for Control Box have been done.
Please do not change anything.**

5. Rear Control Box (**Minor**) Operation Introduction: (The parameters have been set, please do not amend anything)



(The button turn Left=ON; Right=OFF)

Firstly, Turn the **Main Power Button** to ON, the Background Lamp at Front Control Box bright. Then you can operate at Rear Control Box.

Secondly, Turn the **Large Circulation** to ON, Turn the **Master Valve** to ON, Turn the **Bitumen Pump** to ON.

Thirdly, As for **Pump Speed Regulation** button, Clockwise Rotation means Increase. Anticlockwise Rotation means Decrease.

Fourthly, As for Master Nozzle button, Put it down position means all nozzles stop working; Put it upper position means all nozzle working.

Fifthly, As for the 18 nozzle button, each button control two spray nozzles.

Manual spraying via rear spray bar by rear console:

Manual spraying via rear spray bar can be used when short-distance, small-area spraying is needed on construction or the automatic control system fails.

1. Turn the “Control Selection” switch on the rear console (as shown in Fig. 14, rear) to the “Rear Console” position, the “Control Mode” to the “Manual” position and the “Asphalt Control Valve” to the “Large Circulation”. Turn on the “Asphalt Pump” switch, and turn on the desired nozzle switches (each for two nozzles). Now the asphalt pump starts to operate and the asphalt runs for large circulation.
2. Start and drive the truck to the starting point of spraying, turn on the “Master Nozzle” switch to start spraying.
3. The spray rate can be adjusted with “Speed Adjustment” knob.

Spraying via handheld spray bar:

1. Connect the rubber hose (as shown in Fig. 13) to the handheld spray bar valve and then securely connect the handheld spray bar.
2. Open the manual oil return valve (No. 7) approx 45°. Open the handheld spray bar valve.
3. Turn the “Asphalt Control Valve” on the rear console (as shown in Fig. 14, rear) to the “Manual” position, and turn on the “Asphalt Pump” switch to start spraying. Adjust the opening of oil return valve according to the atomization condition.



Pay attention to the following when spraying the asphalt:

1. Never stand on the rear platform during spraying to ensure safety.
2. When shifting the gearbox and power take-off, make sure to disengage the truck clutch; otherwise, the gear may be easy to be damaged.
3. During spraying, drive the truck at a constant speed and do not suddenly depress the accelerator pedal.
4. If the spray rate is inaccurate, set the internal parameters by accessing the control system. In this case, refer to the MT-1C Controller User’s Manual, or contact our after-sales service department.

(VI) Cleaning of the Asphalt Pump and the Pipe

Since asphalt will be solidified when the temperature is low, the filter, asphalt pump, pipes and nozzles shall be cleaned upon completion of operation or when the truck is transferred to another construction site. Otherwise, they cannot work next time. The cleaning methods are as follows:

After automatic spraying via rear spray bar:

1. Close the oil inlet valve (No. 1) (as shown Fig. 8), and open the manual oil return valve (No. 7). Turn the "Control Selection" switch on the rear console (as shown in Fig. 14, rear) to the "Rear Console" position, the "Asphalt Control Valve" to the "Manual Spraying" position. Turn on the "Asphalt Pump" switch. Open the **main pipe air valve** (as shown in Fig. 17), turn the "Asphalt Control Valve" to the "Blow Nozzle", and close the manual oil return valve (No. 7). In this case, the asphalt inside the pipes will be blown into the tank.
2. Close the main pipe air valve (see Figure 17) first, open the diesel inlet copper ball valve, and keep the "Asphalt Control Valve" at "Blow Nozzle" position. Open the "Main Nozzle" switch and the individual nozzle switches. Run the asphalt pump for 2 to 3 minutes to suck diesel into the asphalt pump, then shut off all switches and diesel inlet copper ball valve. The cleaning of the asphalt pump is completed.
3. Automatic nozzle cleaning: turn on the "Nozzle Cleaning" switch on the rear console (as shown in Fig. 14, rear) (the main power should be turned off, then turned on). Open **oil return pipe air valve** (as shown in Fig. 17), and start automatic nozzle cleaning which can be conducted twice.
4. Close the **oil return pipe air valve** first, and then turn off "Nozzle Cleaning" switch. Upon completion of nozzle cleaning, close all valves.



Fig. 17 Valves for cleaning the asphalt pump and pipes

1. Diesel inlet copper ball valve 2. Main pipe air valve 3. Handheld spray bar air valve

Rear spraying via handheld spray bar:

1. Close the oil inlet valve (No. 1) (as shown in Fig. 8), open the manual oil return valve (No. 7), and turn on the "Asphalt Pump" switch. Open the **main pipe air valve** (as shown in Fig. 17) to purge the asphalt remained in the pipe into the tank.
2. Close the **main pipe air valve**, open the diesel inlet copper ball valves (as shown in Fig. 17), and run the asphalt pump at low speed for 2 to 3 minutes. Cleaning of the asphalt pump is finished.
3. Close the diesel inlet copper ball valve and the manual oil return valve (No. 7), and open the **handheld spray bar air valve** (as shown in Fig. 17). Purge out the asphalt remained in the handheld spray hose, handheld spray bar and nozzles.
4. Upon completion of cleaning, close **all the valves**.



Pay attention to the following during pipe cleaning operation:

1. Owing to high temperature of asphalt and pipes, operator shall wear working clothes, gloves and protective helmet during cleaning.
2. Cleaning must be done immediately **upon completion of spraying**; otherwise, the asphalt will be solidified and cannot be removed.
3. Upon completion of cleaning, make sure to close tightly the diesel inlet and outlet copper ball valves and the air valve.

(VII) Completion of Construction

To ensure smooth operation in the next day, the following procedures must be fulfilled when the above-mentioned cleaning operation is finished.

1. Make sure to drain off the asphalt remained in the tank. If hot asphalt is firmly solidified at the tank bottom and will be very difficult to melt on the next day. For emulsified asphalt, deposits might be generated and severely clog the pump on the next day.
2. Open the asphalt filter cover, remove the strainer and put it into diesel for a thorough cleaning. Pour 2L diesel into the filter, put back the filter and tighten the cover. Apply high-temperature grease (7020 kiln bearing grease) at sealing positions for sealing and easy opening next time.
3. Check that all asphalt valves, diesel valves and air valves are closed.
4. Close main air supply valve (on the truck air reservoir) and the power switches on the front and rear console.
5. Retract the right and left rear spray bars and lift the rear spray bar. Confirm that the hook is hung on firmly.

IV. Technical Maintenance and Lubrication

(I). Running-in Maintenance of a New Truck

1. The running-in period for a new truck is 2500km trip distance or 60-hour operation.
2. For a new truck with a trip distance less than 2500 km, its chassis shall be subject to a running-in service at an authorized service station.
3. Service shall be carried out in exact accordance with the section “Running-in Period” in the User’s Manual.
4. Within running-in period, the distributor truck shall be driven at low speed and loaded below 60% of the rated load.
5. Daily check the bolt tightening of bolts on each part. Check each pipe connection for asphalt, fuel, hydraulic oil, compressed air and cooling water for any leakage or looseness.
6. Check all electric switches and connectors for any looseness or abnormal operation.

(II) Technical Maintenance and Lubrication

During the service process, technical maintenance should be carried out for the distributor truck on schedule to ensure a failure-free operation of the machine and to maximize its service life.

Except the chassis, the distributor truck must be subjected to various levels of technical maintenance and lubrication in strict accordance with the User’s Manual. Besides that, regular maintenance and lubrication to each working system must be provided.

1. Lubrication of power train:

After each 200-hour operation, drive shaft and pump transmission should be greased (with general lithium based grease for automobile according to GB/T5671-1995).

2. Maintenance and lubrication of generator
 - a. Clean the air filter element after each 100-hour operation.
 - b. Check the oil level regularly. Immediately fill oil (gasoline engine oil SAE10W-30) when the oil level is lower than the mark line.
 - c. Always clean the dirt and asphalt stuck on the surface.

3. Maintenance and lubrication of asphalt pump:
 - a. Regularly check the input collar of the asphalt pump for oil leakage. Screw in the compressing nut 1 to 2 rounds.
 - b. At the end of each 100-hour operation period, apply 1 or 2 more sealing packings. During applying the sealing packing, apply high-temperature grease to the inner surface of the collars, sealing packings and hold-down nuts.
4. Maintenance of combustion system:
 - a. Clean the carbon deposit off the burner after each 100-hour operation.
 - b. Clean the fuel tank after each 300-hour operation.
5. Maintenance of hydraulic system:
 - a. Replace the hydraulic oil (with Great Wall 68# abrasion-resistant hydraulic oil) after the first 3-month (or 300-hour) operation. After that, replace the hydraulic oil and clean the hydraulic oil tank every year. The hydraulic oil that is not deteriorated can be reused after being filtrated it by using a filter less than 5 μ m.
 - b. After the first 3-month (or 300-hour) operation, the filter element for oil sucking and return oil shall be replaced. After that, they should be replaced yearly.
 - c. Check each pipe connection for any leakage, and replace the seal ring in time.
 - d. Check the hydraulic oil level regularly and refill it immediately when the level is below the mark line.
6. Maintenance of heat transfer oil system:
 - a. Check the pipe connection for any leakage, and replace the seal ring in time.
 - b. Fill heat transfer oil in the expansion tank of heat transfer oil (Great Wall 320#).

V. Troubleshooting

The following table is for reference only. If you cannot judge the fault or remove it correctly, please consult our after-sales service department.

No.	Fault	Possible cause	Solution
1	The power take-off Cannot be shifted.	<ol style="list-style-type: none"> Lack of pressure or air leakage from the exhaust pipe may exist. An electrical switch may be damaged. A solenoid valve may be damaged. 	<ol style="list-style-type: none"> Check whether the air compressor or pressure regulating valve fails. In case of failure, replace the exhaust pipe. Replace the switch. Replace the solenoid valve.
2	The gearbox Cannot be shifted.	<ol style="list-style-type: none"> Lack of pressure, or air leakage from the exhaust pipe may exist. An electrical switch may be damaged. A solenoid valve may be damaged. The small cylinder may be damaged or the connection may come off. The truck clutch may not disengage completely. 	<ol style="list-style-type: none"> Ditto. Ditto. Ditto. Replace the small cylinder or securely fix the connection. Adjust the truck clutch.
3	The asphalt pump does not work.	<ol style="list-style-type: none"> The hydraulic system may fail. A blocking solid object may exist. Seizing asphalt may exist. 	<ol style="list-style-type: none"> Remove the hydraulic system failure. Dismantle the asphalt pump to remove solids. Wash the asphalt pump with diesel and bake the waste gas.
4	The hydraulic motor does not work or turns over at a lower speed.	<ol style="list-style-type: none"> The overflow valve may be seized, or the pressure may be low. 	<ol style="list-style-type: none"> Dismantle and wash the overflow valve, and readjust the pressure.

No.	Fault	Possible cause	Solution
		2、 The reversal valve coil may have no power or burnt out. 3、 The oil temperature may be excessively high, or there may be no pressure. 4、 The hydraulic pump or motor may be worn out.	2、 Check the circuit or replace the coil. 3、 Will be described in the column below. 4、 Replace the hydraulic pump or motor.
5	The temperature of hydraulic oil is high (85°C or above).	1、 The hydraulic oil is insufficient. 2、 There may be too much resistance to the asphalt pump, or oil leak from the overflow valve under high pressure for a long period. 3、 The oil suction filter may be blocked.	1、 Fill hydraulic oil. 2、 Check the asphalt pump and the overflow valve. 3、 Clean the filter.
6	The burner cannot be ignited,	1、 There may be no power supply. 2、 The filter may be soiled, or fuel pipe may be blocked. 3、 Carbon deposit or blockage of burner may exist. 4、 Oil supply pump may be worn out, or oil pressure may be too low.	1、 Check the generator and the switches in temperature control box. 2、 Clean the filter and blow the oil pipe with compressed air. 3、 Dismantle and wash the burner. 4、 Replace the oil supply pump of burner.
7	The asphalt pump works normally, but Sprays no asphalt.	1、 The asphalt valve may be placed at a wrong position. 2、 The suction oil inlet may be blocked by asphalt. 3、 The asphalt filter may be blocked.	1、 Adjust the valve position by following the instructions described in Section 1, (V), III. 2、 If hot asphalt is used, wait for self melting, or heat it with heat transfer oil. 3、 Take out and wash it.

No.	Fault	Possible cause	Solution
		4、 The oil outlet pipe may be blocked by asphalt.	4、 Heat, bake or dredge the oil outlet pipe with heat transfer oil.
8	The spray pressure is insufficient or intermittent.	1、 The asphalt filter strainer may be blocked. 2、 Filter cover may have a air leakage. 3、 The main pipe air valve may be not closed tightly. 4、 The temperature of asphalt may be too low. 5、 The oil return valve (No. 7) may be not closed. 6、 The asphalt pump may be worn out. 7、 Operation of hydraulic system may be not stable. 8、 The control system may fail.	1、 Remove the trouble. 2、 Tightly seal and cover. 3、 Close the valve tightly. 4、 Heat asphalt to the designated temperature 5、 Place the oil return valve (No. 7) to the proper position. 6、 Repair or replace the asphalt pump. 7、 Check the hydraulic system. 8、 Check the actual pump speed and voltage.
9	Asphalt is not sprayed evenly.	1、 The spray pressure may be insufficient. 2、 The nozzle may be blocked by foreign matters.	1、 Check and adjust as the above mentioned. 2、 Remove the foreign matters.
10	Cannot add asphalt by self-suction	1、 The oil inlet valve may be not closed securely, or the oil return valve (No. 7) may be not opened. 2、 The filter cap may have an air leakage. 3、 The main pipe air valve may be not closed tightly.	1、 Check the valve. 2、 Tightly seal and cover. 3、 Close it tightly. 4、 Heat asphalt to the designated temperature

No.	Fault	Possible cause	Solution
		4、 The temperature of asphalt is may be too low. 5、 Gas leakages from the joint connection of the self-suction pipe may exist. 6、 The truck may be too far away or too close to the asphalt storage tank.	5、 Add sealing gasket and press it tightly. 6、 Change the condition; otherwise, do not start self-suction.
11	Heat transfer oil overflows.	1、 Heat transfer oil may be excessively full. 2、 The heat transfer oil system may have water entry. 3、 Heat transfer oil newly filled may be a type from a different trademark or its water content may be too high.	1、 Reduce heat transfer oil. 2、 Heat up and dewater the system. 3、 Replace the heat transfer oil.
12	Asphalt pump leaks asphalt.	The packing in the place of collar may be worn out.	Appropriately screw in the nut, or add packing.

Meticulous Management

Elaborative Manufacture

Satisfy the Customer Strive for Excellence

howotrucks.com
whatsapp: 0086 136 4729 7999